

REV.	DESCRIPTION	DATE
A	NEW DRAWING	7/30/2007

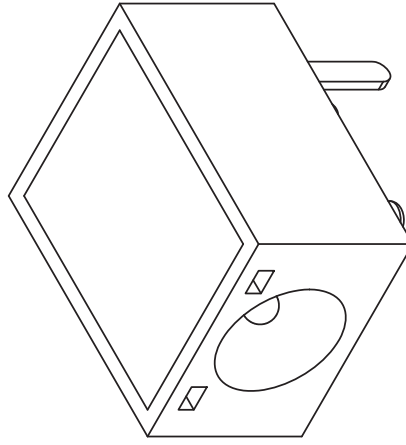

TOLERANCE:
 X.X±0.2mm
 X.XX±0.1mm
 X.XXX±0.05mm

SPECIFICATIONS:
 RATING: 16V DC@ 2A
 CONTACT RESISTANCE: 50m OHMS MAX
 INSULATION RESISTANCE: 100M OHMS MIN: 500V DC
 VOLTAGE WITHSTAND: 500V AC R.M.S. FOR 1 MINUTE
 LIFE: 5,000 CYCLES
 OPERATING TEMP: -25° ~ +85°C

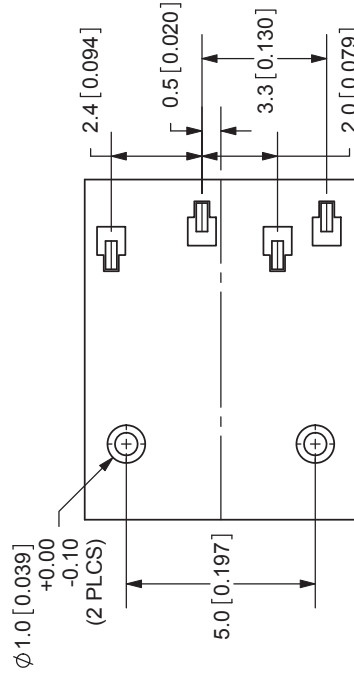
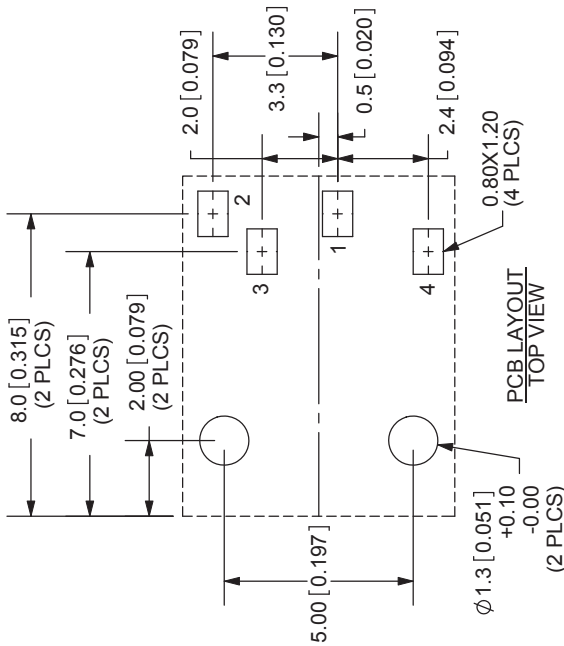
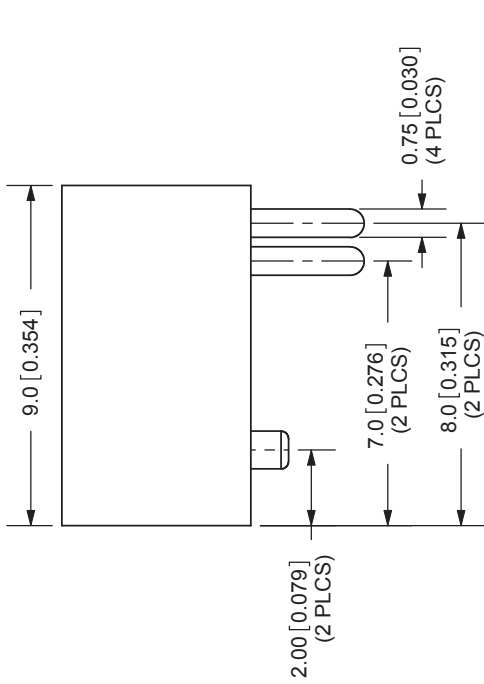
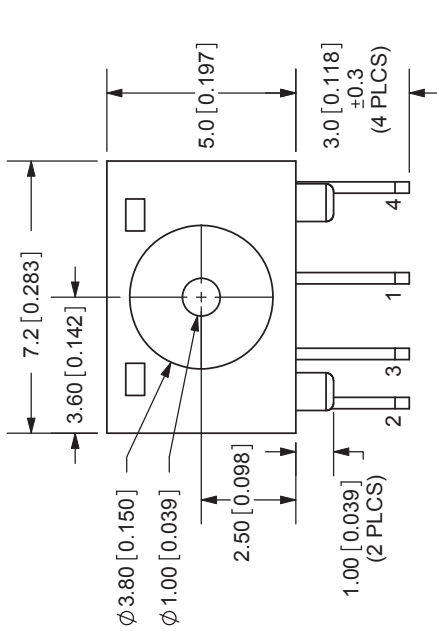

CUI INC
 20050 SW 112th Ave.
 Tualatin, OR 97062
 Phone: 503-612-2300
 800-275-4899
 Fax: 503-612-2383
 Website: www.cui.com

MODEL NO.	PJ-052C
SCHEMATIC	

CENTER PIN DIAMETER 1.00mm Dia.

TITLE:	DC POWER JACK	REV:	A
PART NO.	PJ-052C	UNITS:	MM [INCHES]
DRAWN BY:	ZRJ	APPROVED BY:	
SCALE:			5:1

	MATERIAL	PLATING
CENTER PIN	Brass	Tin
TERMINAL 1	Brass	Tin
TERMINAL 2	Copper Alloy	Tin
TERMINAL 3	Brass	Tin
TERMINAL 4	Copper Alloy	Tin
BODY	PA66	
INSULATOR	PA66	